

AST

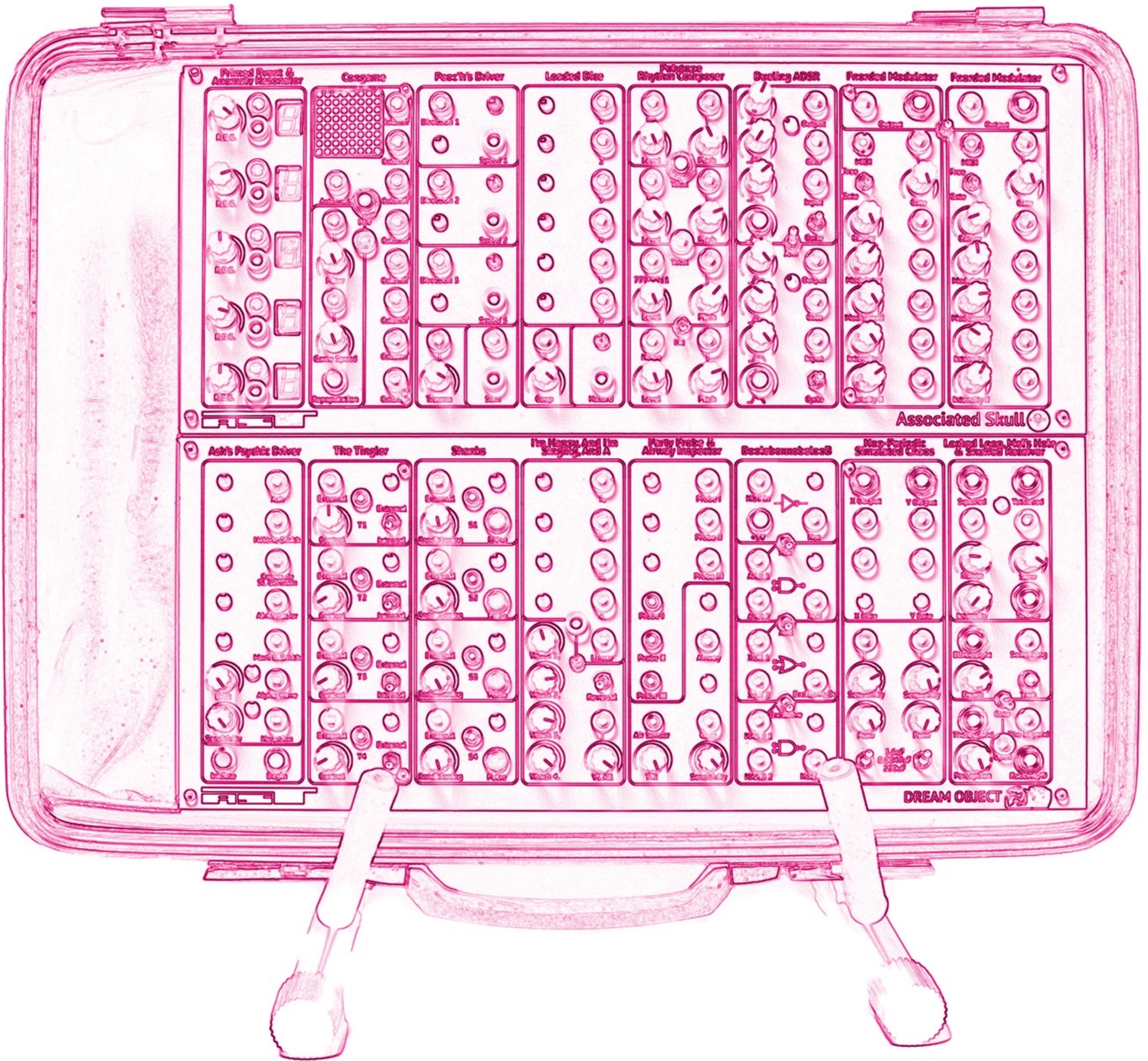

AST125 INFRINGED REALISM construct guide

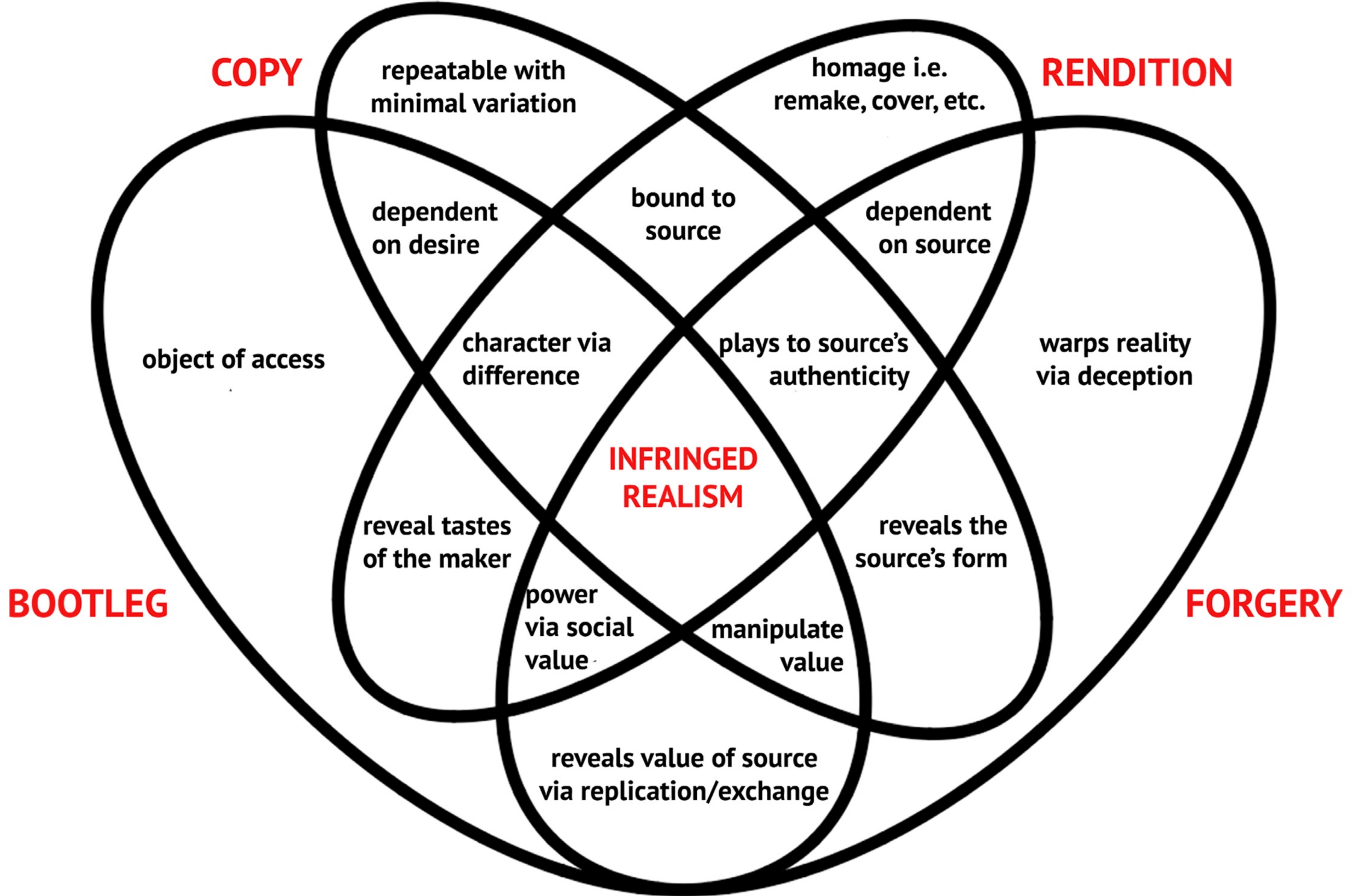

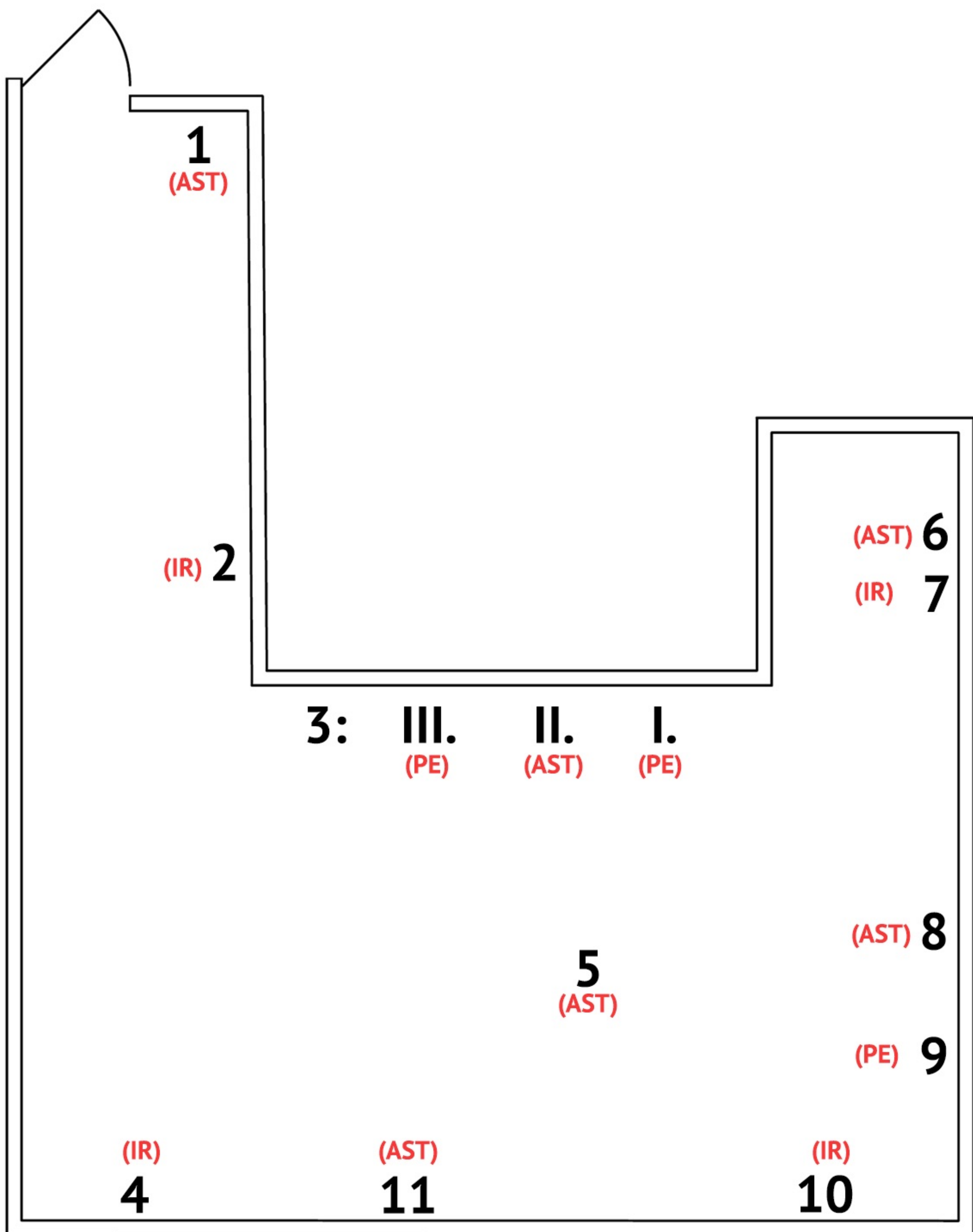

1. The Boats (after Jeffrey Vallance)
2. Global Adversarial Network II: Reverse Engineered Chill Out/
Dolly's Ladder (1917-2012)
3. Research ANd Development: Major Gifts I-III.
 - I. Seagate Erased (2007-2011)
 - II. Ice Bag Scale–SD (after Claes Oldenburg in the style of Elaine Sturtevant)
 - III. Model of Captured RQ-170 Drone
4. Light Functionalism: FreeAgent
5. Inhuman Labor I: Pigeonblogspot.com (after delinquent accounts)
6. 33 1/3 Proposal (after Perry Webb)
7. PYT VSN (after Marjorie Cameron)
8. Accursed Shared System
9. The Serge Stripped Bare (after Serge Tcherepnin)
10. Suprematist Ignignokt (after 2007 Boston Mooninite Panic)
11. Saied Drone Keychain

TYOLOGY

AST (AST): Products & fabrication services provided by AST electronics. While not artworks, the services of AST have been crucial to the development & formation of artworks for institutions, events, & artists.

INFRINGED REALISM (IR): Objects that function in equal use to it's referent but apart due to access. Not what things 'mean' but 'do', & do to their source. Inversion, use, & misuse of source & tastes of the maker are central.

PERSONAL EFFECTS (PE): Research & development materials central to the development of the artistic practice of Alan S. Tofighi & AST electronics.

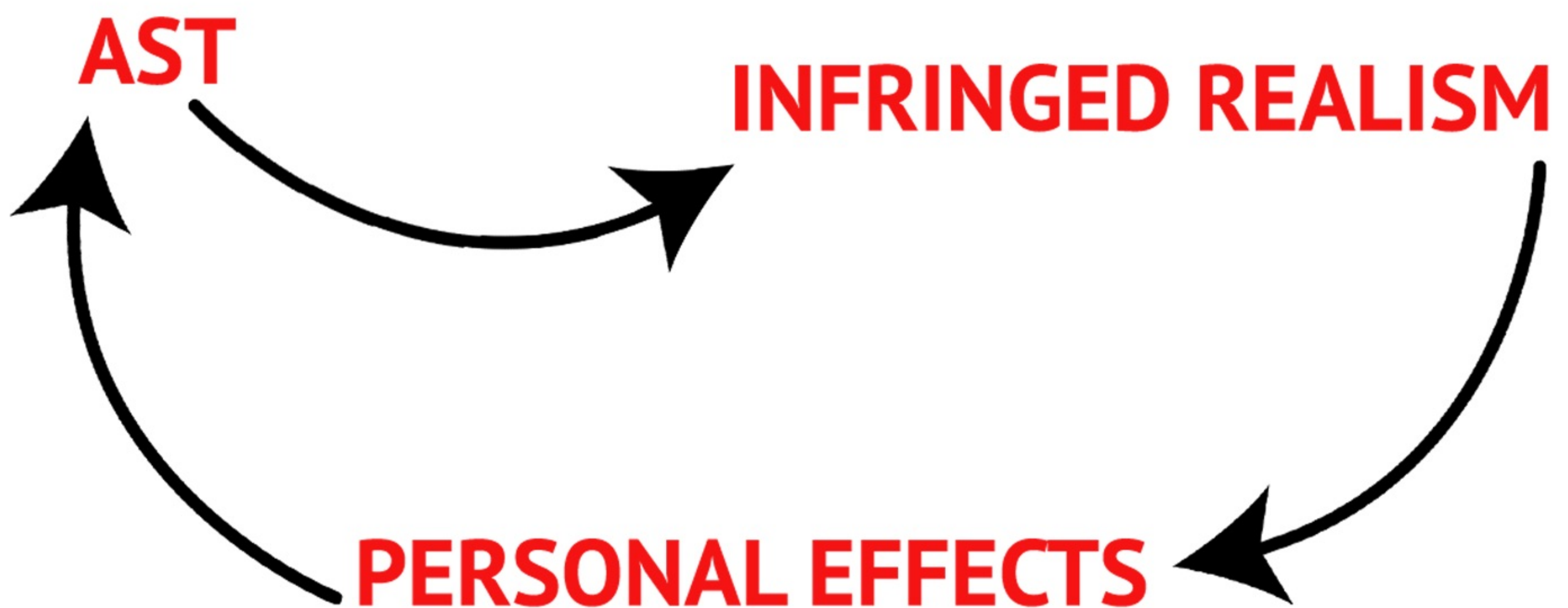

BILL OF MATERIALS

1. **The Boats (after Jeffrey Vallance)** subwoofer, circuitry by AST. 2026.

AST113 The Boats Dual Sub Generator. Bootleg of Sensurround circuitry & speakers designed to simulate earthquakes for the 1974 film *Earthquake*. The speakers were recovered by Jeffrey Vallance in 1975 for pioneering inaudible band The Boats, to be revived due to the new circuitry.

2. **Global Adversarial Network II: Reverse Engineered Chill Out/Dolly's Ladder (1917-2012)** oil on canvas, Musou black paint, 24" x 26". 2026.

Bootleg genealogy painted from memory: Dolly the sheep, the KLF's drop out letter tied to a dead sheep, Grateful Dead 'Marching Bear' arm, detail of a bootleg Louis Vuitton logo, surface of Iranian toy drone mailed to Barack Obama, Roland TB-303 ladder diode schematic, chemical formula for MDMA/Methamphetamine & Razzle Dazzle camo pattern.

3. **Research ANd Development: Major Gifts I-III.**

I. **Seagate Erased (2007-2011)** brushed aluminum, plastic, LED, unquantifiably valuable contents. 2011.

250 GB Seagate FreeAgent external hard drive given to artist on their 16th birthday to pirate media. Seminal autodidactic tool. Broken, a state of continual degradation & set free.

II. **Ice Bag Scale – SD (after Claes Oldenburg in the style of Elaine Sturtevant)** ice bag, rotating disc, servo motor, circuitry by AST. 2025.

AST100. 1/18th bootleg of Claes Oldenburg's *Giant Ice Bag (1969–1970)* in collaboration with Walt Disney (WED) but completed by Krofft Enterprises via LACMA's Art & Technology program. Made as a gift to SeeVa Dawne as part of their research on the original *Giant Ice Bag* for their book *Desert Rubble*.

III. **Model of Captured RQ-170** Drone cardboard, silkscreen, plastic. 2012.

1/80 scale model of the classified American RQ-170 drone captured after entering Iranian airspace in 2011. After Barack Obama pled for the drones return, a pink version of the model was offered as a gift instead.

4. **Light Functionalism: FreeAgent** airbrush on canvas, Musuo black paint. 16" x 40". 2026.

Painting of artists first external hard drive.

5. **Inhuman Labor I: Pigeonblogspot.com (after delinquent accounts)** faux taxidermy pigeon, miniature backpack, circuitry by AST. 2025.

AST124. GPS equipped air quality sensors built by AST for the relaunch of Beatriz da Costa's PigeonBlog as part of Getty's *PST ART: Art & Science Collide* (2024). Bootlegged to recoup funds from unpaid labor to AST as of October 2024.

6. **33 1/3 Proposal (after Perry Webb)** paper, misprint 33 1/3 book, mirror mounts. 2026.

Mockup for a book on Cuturcide's 1986 album of appropriation *Tacky Souvenirs of Pre-Revolutionary America*. Acerbic & detoured lyrics sung over home taped recordings of top 40-hits. Jacket placed over a misprint 33 $\frac{1}{3}$ book where Pulp's *This Is Gardcore* instead contains the Clash's *Sandinista*.

7. **PYT VSN (after Marjorie Cameron)** tracing paper, ink, bootleg book, mirror mounts. 2026.

To scale bootlegged inversion of the unparalleled Marjorie Cameron's *Untitled (Peyote Vision)* shown by Wallace Berman at Ferus Gallery in 1957 before arrest by the vice squad. Inserted into a page selected by chance of a bootlegged edition of Jack Parson's *Freedom is a Two-Edged Sword*.

8. Accursed Shared System suitcase, synthetic leather, aluminum, silkscreen, jacks, LEDs, circuitry by AST. 2024.

AST80. A synth that does not make sound but control of sound, or motors, via statistical randomness, brainwave headsets, Raudive Diodes, etc. via the Associated Skull & Dream Object panels. Named after Jim Shaw's *Dream Object* series, the proto-goth Associated Skull bands, Georges Bataille's *The Accursed Share* & Make Noise's flagship synth, the *Shared System*.

9. The Serge Stripped Bare (after Serge Tcherepnin) scrap wood, masonite board, paper, leather, metal, rotating disc. 2025.

Former housing of Artist's bootleg Serge Synthesizer. A perpetual prototype for self taught electronics before stripped for parts & rehoused in 2025. The Serge was developed in 1974 as 'The People's synthesizer' at CalArts as a DIY bootleg of otherwise financially unattainable systems. Composers could then work after losing access to studios post-graduation.

10. Suprematist Ignignokt (after 2007 Boston Mooninite Panic) 330 green LED's, stripboard, circuitry by AST. 2026.

AST121. Bootleg of a LED panel featuring the character 'Ignignokt' from & for the 2007 film *Aqua Teen Hunger force Colon Movie Film for Theaters*. The panels were placed in public as a marketing stunt but mistaken for explosives & detonated by the Boston Police Department's bomb squad.

11. Saied Drone Keychain resin, metal, keychain. 2026.

AST123. 1/80 scale model of the Iranian toy drone. A third level bootleg of the original RQ-170 drone which was reverse engineered into the Shahed Drone used by the IRGC in the 2026 United States regime change operation. As of writing the IRGC began making keychains of their Shahed drone as well.

HOUSTON CONTINUUM

1980: Houston, TX Culturcide is formed by Mark Flood aka Perry Webb & Jim Craine later joined by Dan Workman.

1986: *Tacky Souvenirs of Pre-Revolutionary America* is released. A gambit accelerating ends to the underground & appropriation. It contains not samples but entire songs taped off the radio accompanied by acerbic detoured lyrics sung over the originals.

Lawsuits are sent to Culturcide, they lie claiming a cease & desist has already been sent. All charges are dropped, escaping the legal hammer unlike Negativland, The KLF, & John Oswald a few years later.

Late 1980's: Chopped & Screwed is invented by DJ Screw at a friend's apartment. Tracks are played & manipulated at drastically lower speeds. A final innovation in music: the performance of time itself.

21st Century : Workman becomes president of Sugarhill Studios producing Beyonce & ZZ Top. Flood's early paintings sell in the 2010's becoming a blue chip artist. Popular forms are now primarily Chopped & Screwed or Culturcide.

CAMERON'S PROPULSION

1951: Marjorie Cameron & husband Jack Parsons hold a party & meet Wallace Berman. 1952 Parsons dies by an explosion in his garage. A distraught Cameron & her art re-enter the world.

1954: Fellow Thelema practitioner Kenneth Anger casts Cameron *In The Inauguration of the Pleasure Dome*. Cameron's energy on set grants her the lead role over Anaïs Nin. An aesthetic shift, never to be reversed, is initiated.

1955: Cameron's holy guardian angel suggests that she cut off her prized hair to ward off vanity. The striking haircut is immortalized via portrait by Berman for the cover of *Semina no. 1*. The era of artists books begins.

1957 Ferus Gallery: A 3 13/16" x 4" reproduction of Cameron's *Untitled (Peyote Vision)* is included in a sculpture of Berman's leading to obscenity charges & his arrest. Publicity forms, Los Angeles becomes a cultural center. 1962 Ferus holds Warhol's first exhibition. Cameron & Berman never exhibit publicly again & form alternative networks.

PRESENT: Questions on a copies potential for aura end. Cameron imbued power to reproductions not as copy but sigil. Post-documentation|infinite working.



Jeffrey Vallance

February 18, 2020 at 6:27 PM ·



GARAGE BAND WITH NO SOUND

"In the mid-70s, I was in a garage band called The Boats; the instruments we played were connected to special Sensurround™ speakers made for the 1974 movie Earthquake. The Sensurround speakers employed a pseudorandom noise generator connected to a control box creating a range of "sound pressures." We'd found four huge beat-up speakers at a swap meet —abandoned by the movie industry when Sensurround fad went out of fashion. Actually the resonance was so low that you couldn't really hear anything, but you felt the vibrations in your body. Different low frequency vibrations would resonate in various parts of one's anatomy, but especially the chest cavity. The floor and walls would rattle as well as anything attached to them. Some objects seemed to dance across the floor while things hung on the walls would clatter and eventually come crashing down. But you'd swear you were hearing music, but it was actually one's own body resonating, as well as the whole damn surroundings. I'd swear that the vibrations stimulated by brain—creating all kinds of weird ideas!"



Like



Comment



Send



You, Doug Harvey and 55 others

1 Share



Alan S Tofighi

WHAT! I never knew this! Reunion and release a record!



THE BOATS

Pseudorandom Noise Generator as used by inaudible band The Boats

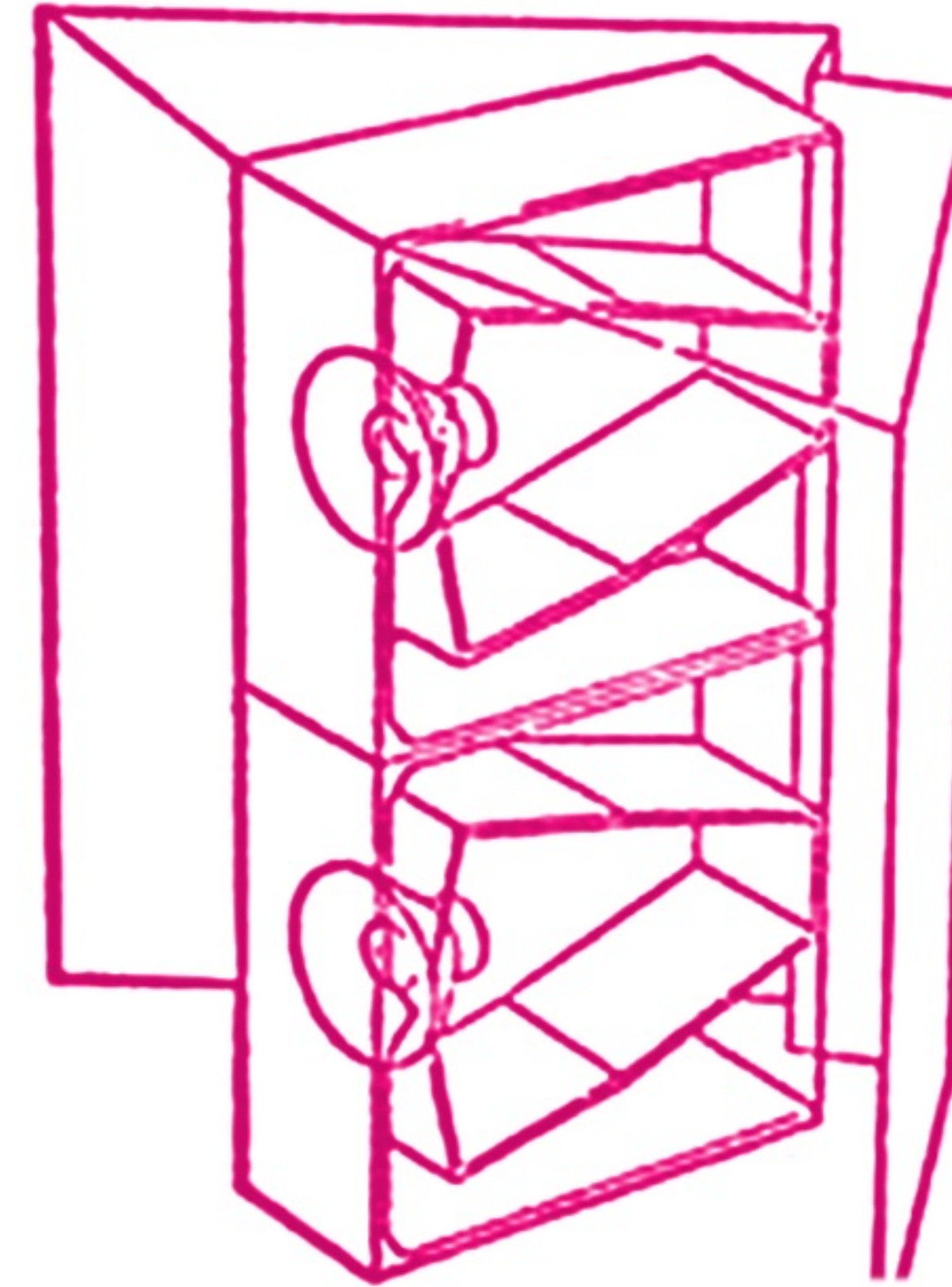
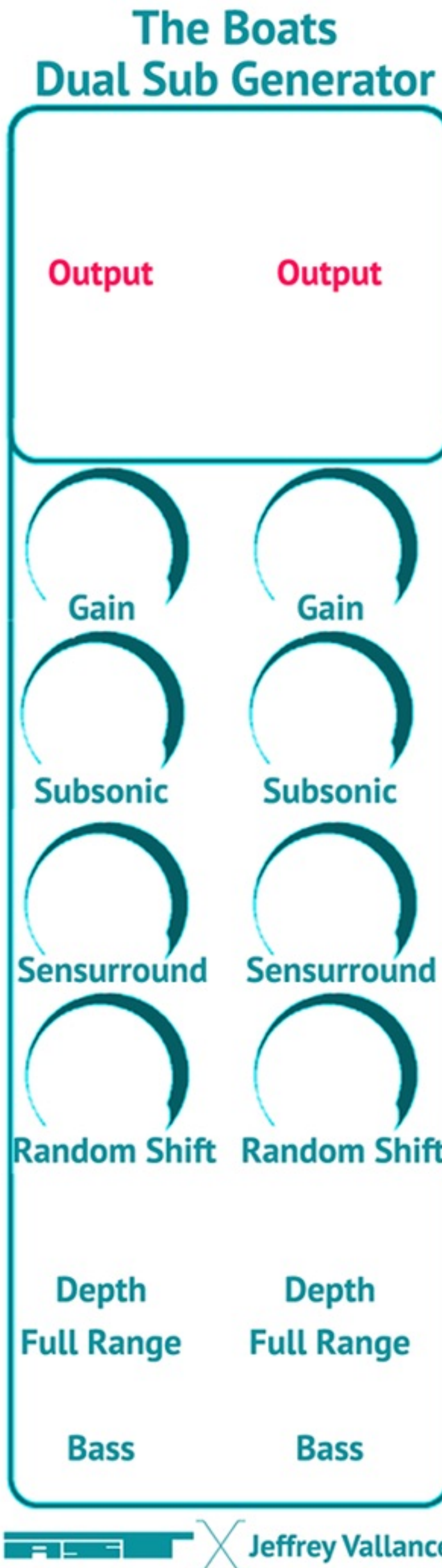
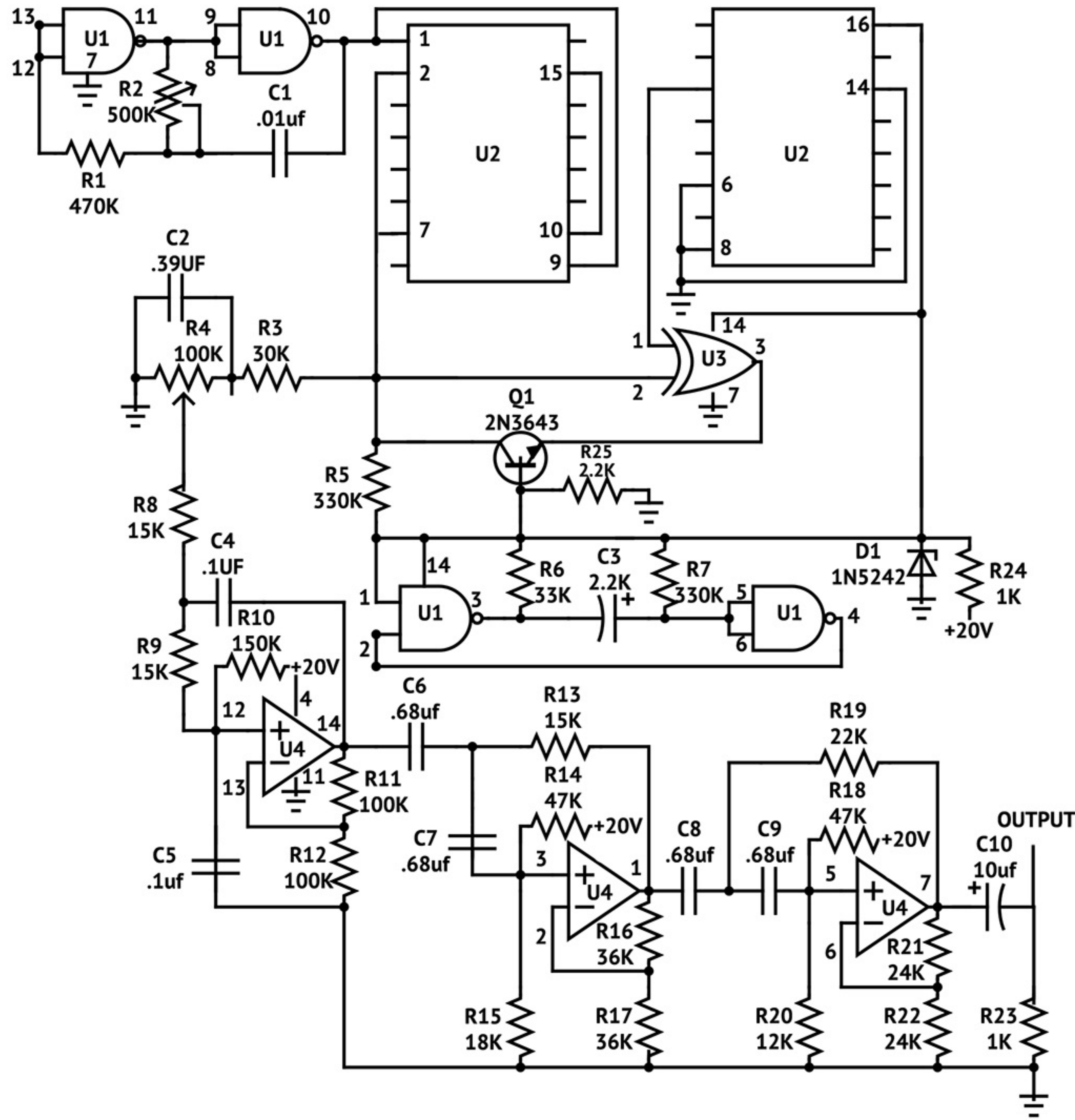

AST113 PCB Bill Of Materials		
TYPE	QTY	DESIGNATOR
INTEGRATED CIRCUIT		
CD4011 Quad 2-Input NAND Gate	x1	U1
CD4015 Dual 4 Stage Shift Register	x1	U2
CD4030 Quad Exclusive OR Gate	x1	U3

LM324 Quad Package OpAmp	x1	U4
RESISTOR		
100k linear		
1k	x2	R23, R24
2k2	x1	R25
12k	x1	R20
15k	x3	R8, R9, R13
18k	x1	R15
22k	x1	R19
30k	x11	R3
33k	x1	R6
24k	x2	R21, R22
36k	x2	R16, R17
47k	x2	R14, R18
100k	x2	R11, R12
150k	x1	R10
330k	x2	R5, R7
470k	x1	R1
POTENTIOMETER		
100k linear	x1	R4
500k linear	x1	R2
DIODE		
1N5242	x1	Q1
TRANSISTOR		
2N3643	x1	D1
CAPACITOR		
.01uf polyester	x1	C1
.1uf ceramic	x2	C4, C5
.39uf polyester	x1	C2,
.68uf polyester	x4	C6, C7, C8, C9
2uf electrolytic	x1	C3
10uf electrolytic	x1	C10



BACKED UP COMMUNITY

July 4, 2007: Hacker cousin gifts

Tofighi a 250 GB Seagate

FreeAgent external

drive preloaded

with music &

instructions

on how to

pirate.

Using

methods of

research learned

from the Boy Scouts,

Tofighi quickly gains

access to media relating

to historic counterculture,

the historical avant-garde, &

textbooks by ways of blogspots,

archive.org, torrenting, & soulseek.

The external drive travels with friends

becoming a communal archive & backup

2014: Entering undergrad, Tofighi learns the

majority of their peers did not know how to use

the internet for deeper research. Academic piracy

websites largely disappeared but workshops are

still held. Predicting the age of streaming &

shuttered access, the communal exchange

as a backup is an unparalleled tool &

method of digital preservation.

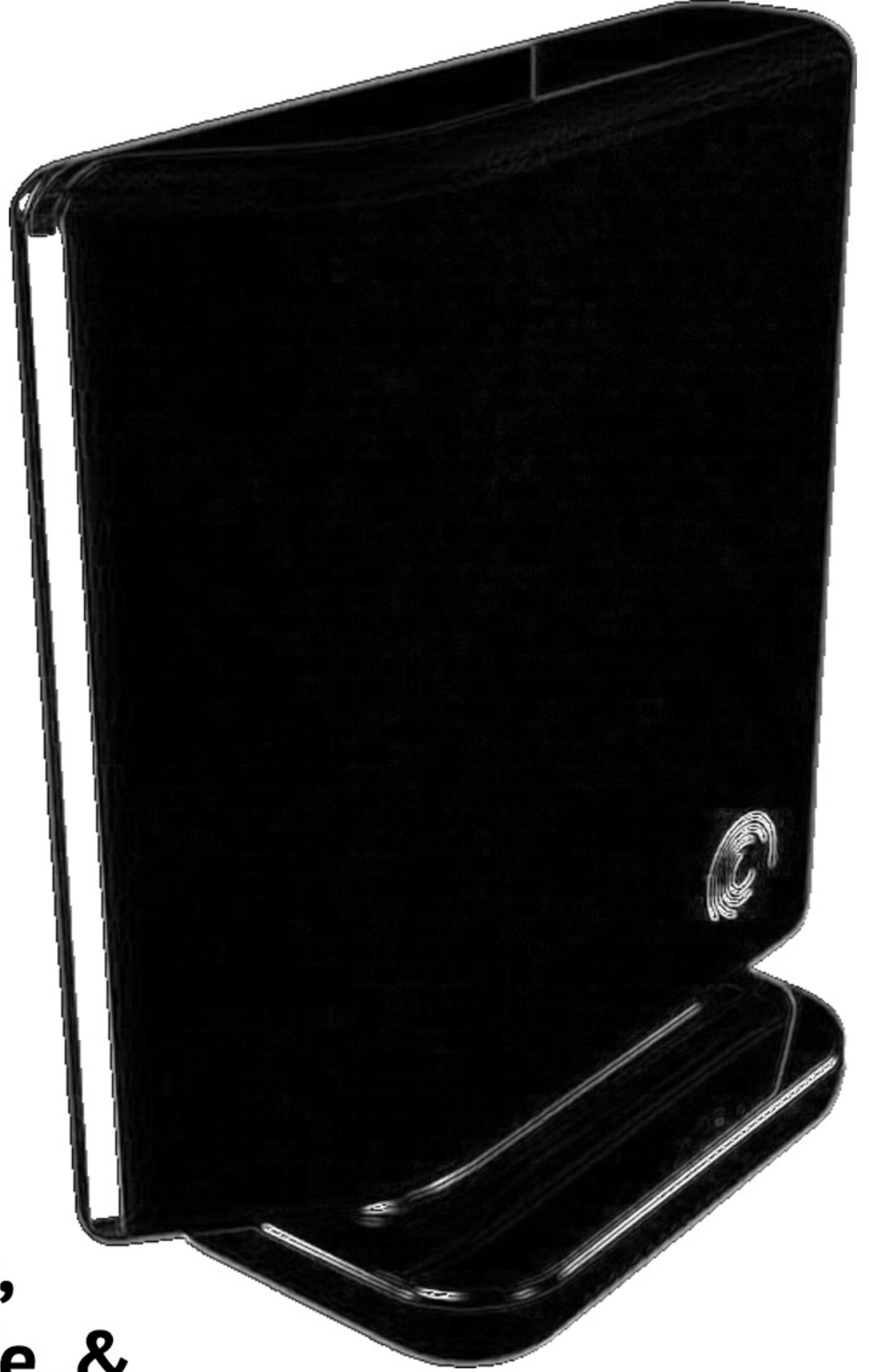

AST Electronics is a fabrication studio specializing in the conceptualization & realization of hypo-specific circuitry founded by Alan S. Tofighi in 2016. Primarily working for artists & institutions, AST designs often result in the construction of circuitry based on abstract sentences, reverse-engineered artworks, and long defunct devices, often of dubious & questionable origin. AST was formed to make otherwise improbable & unaffordable projects possible. AST excels in the creation of tools & instruments of complex results by simple means & sliding pay scales.

Like many other companies AST began by reverse engineering extant products to make them unrecognizable from the source. This process is worn on its face. Perpetual prototypes, & boutique bootlegs are AST's mission.

AST would like to thank MA, SB, DB, RC, SD, GJ, TJ, RM, RTM, TP, LP, CS, ST, CW, MW & all who have helped in the service of AST.